



OFFICINE GULLO
FIRENZE



PVS4 PVS8

**ELECTRICAL GLASS CERAMIC COOKING TOP FOR
RESIDENTIAL AND PROFESSIONAL USE**

**INSTRUCTIONS
for installation and use**

CAUTION

1. These safety directions apply to different kinds of appliances. Please identify correctly the specific appliance in your possession (check the tag showing the characteristics).
2. Before using the appliance, read the instruction manual carefully, as it contains important safety information on the proper installation, use and maintenance of the appliance. Please keep the instruction manual for further reference.
3. The appliance's electrical safety is guaranteed only if the electrical system is earthed in accordance with the relevant regulations. It is of the utmost importance to follow such regulations; when in doubt, please consult a qualified electrician to have the electrical system thoroughly checked. The manufacturer declines all responsibility for damage caused by a badly-earthed electrical system
4. Before connecting the appliance, make sure that the appliance's technical characteristics shown on the tag correspond to those of the electrical system and gas distribution network.
5. Make sure that the electrical system and sockets can handle the appliance's maximum power consumption as shown on the tag. When in doubt, please consult a qualified electrician.
6. The appliance should be connected to the electric supply line by means of an omnipolar switch with a minimum contact opening of 3 mm
7. If the power socket is not compatible with the plug, replace the socket with a proper one and consult a qualified electrician to make sure that the cable size can handle the appliance's maximum power consumption. The use of adapters, multiple power boards and extension cords is not recommended.
8. When not in use, switch off the general power supply to the appliance and close the gas supply valve.
9. Do not obstruct the appliance's cooling or heat dissipation vents.
10. In case of damage to the appliance's power cord, it must be replaced exclusively by the manufacturer's authorized service center.
11. The appliance must be used only for the purposes for which it has been expressly designed (cooking). All other uses (such as the heating of a room) are considered inappropriate and therefore dangerous. The manufacturer declines all responsibility for damage resulting from improper use of the appliance.
12. The use of any electric appliance implies the observance of some basic rules. More specifically:
 - A. Do not touch the appliance with wet or damp hands or feet;
 - B. Do not use the appliance with bare feet;
 - C. Avoid the use of extension cords and, if necessary, take all precautions;
 - D. Do not pull the power cord to disconnect the plug from the power socket;
 - E. Do not leave the appliance exposed to atmospheric agents (rain, sun, etc.);
 - F. Do not allow children or untrained persons to use the appliance.
13. Before cleaning the appliance or performing maintenance work, disconnect the appliance by pulling the plug out of the power socket or turning off the main switch.
14. In case of failure or malfunction, turn the appliance off, close the gas supply valve and do not attempt to carry out any repairs, which must be done exclusively by an authorized service center.

Request the use of original spare parts only. Failure to comply with the above recommendations may compromise the appliance's safety

FIG.A

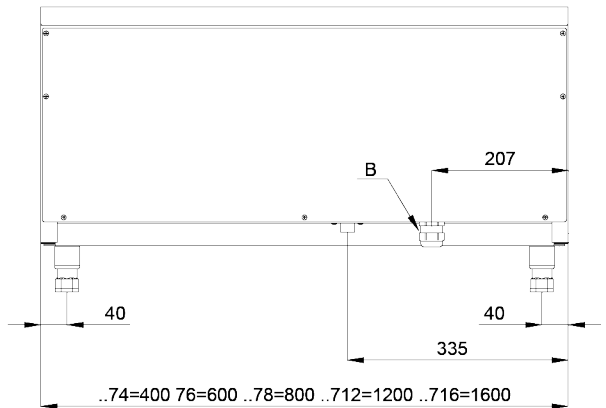
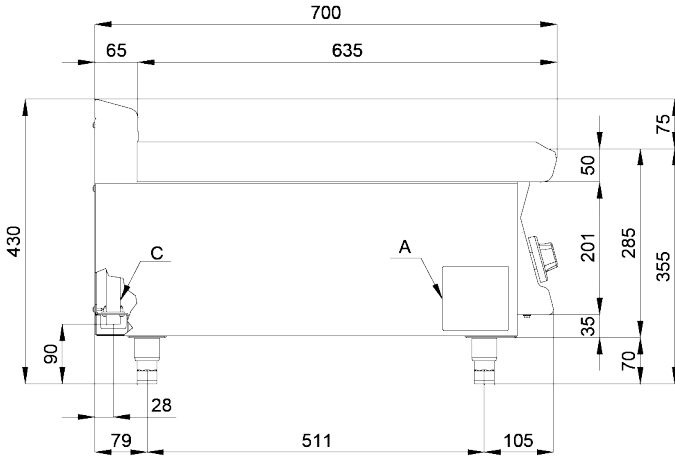

- A. Data Plate
- B. Electrical connection

FIG.B

WIRING DIAGRAM PVS4

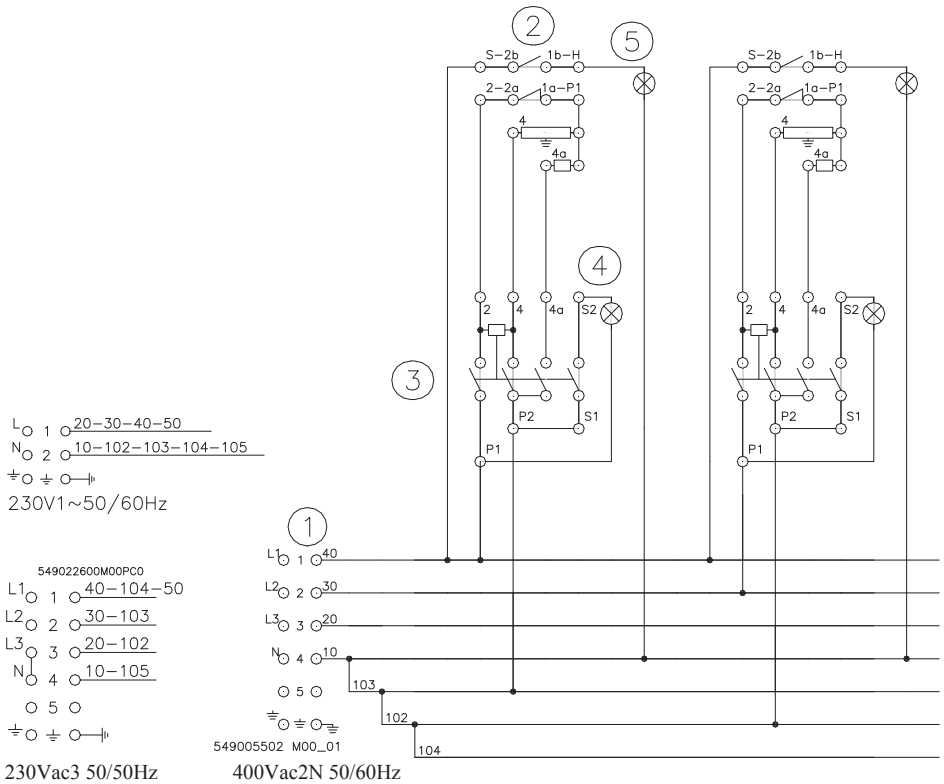

1. Junction-box
2. Hotplate
3. Energy regulator
4. White light
5. Remaining heat pilot

FIG.C

WIRING DIAGRAM PVS8

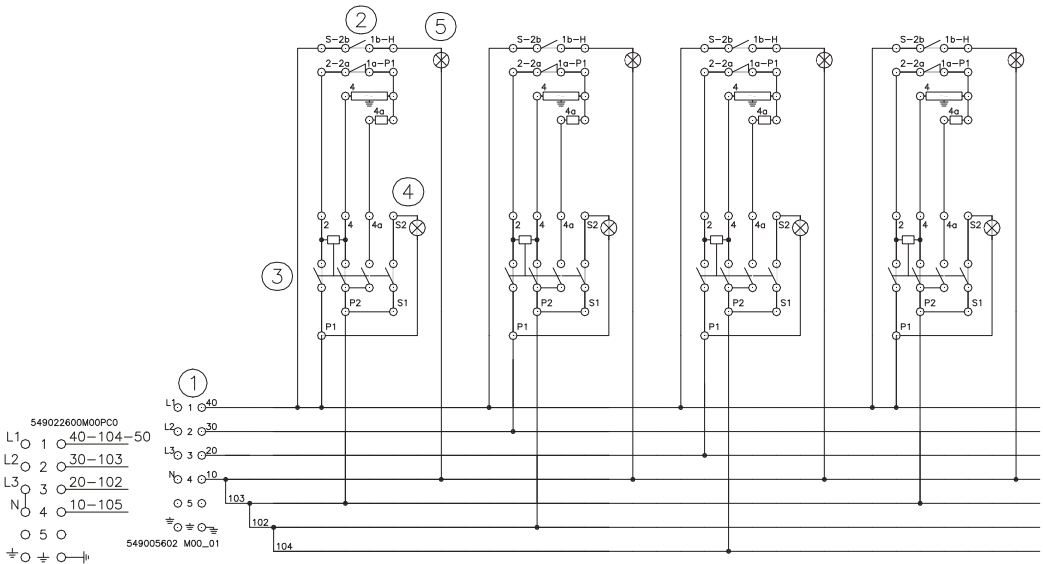

230Vac3 50/50Hz 400Vac3N 50/60Hz

1. Junction-box
2. Hotplate
3. Energy regulator
4. White light
5. Remaining heat pilot

INDEX

TECHNICAL ELECTRICAL DATA TABLE.....	8
TRANSFORMATION.....	8
DECLARATION OF COMPLIANCE.....	8
INSTRUCTIONS FOR INSTALLATION.....	8
LAWS, TECHNICAL RULES AND NORMS.....	8
ELECTRIC CONNECTION.....	9
EQUIPOTENTIAL.....	9
STARTING UP.....	9
INSTRUCTIONS FOR USE.....	9
TURNING ON.....	10
CLEANING AND MAINTENANCE.....	11
PROCEDURE TO FOLLOW IF THE APPLIANCE IS NOT GOING TO BE USED FOR SOME TIME.....	12
PROCEDURE TO FOLLOW IN THE EVENT OF A BREAKDOWN....	12
MAINTENANCE (ONLY FOR QUALIFIED PERSONNEL).....	12
ACCESSIBILITY.....	12

TECHNICAL ELECTRICAL DATA TABLE

MODELS	DIMENSIONS cm	POWER SUPPLY	Power max kW	Absorbition max A	Power supply cable
PVS4	40 x 70 x 29h	400V 2N 50/60Hz	5	10,9	4 x 1.5 mm ²
PVS8	40 x 70 x 29h	400V 3N 50/60 Hz	10	21,7	5 x 2.5 mm ²

TRANSFORMATION

MODELS	POWER SUPPLY	Power max kW	Absorbition max A	Power supply cable
PVS4	230Vac 50/60Hz	5 kW	21,74 A	3 x 2,5 mm ²
PVS8	230Vac3 50/60Hz	10 kW	28,76 A	4 x 4 mm ²

DECLARATION OF COMPLIANCE

The manufacturer declares that the appliances are compliant with the prescriptions of the EEC norm 90/396. The installation must be done observing the norms in force particularly concerning room ventilation and discharging gas emissions.

N.B.: The manufacturer declines any responsibility for direct or indirect damage caused by improper or incorrect installation, alterations, maintenance or use of the appliance, as in all the other cases considered in the items of our sales conditions.

INSTRUCTIONS FOR INSTALLATION

When fitting, the appliance must be levelled using a spirit level; slight differences of level can be adjusted by screwing or unscrewing the adjustable feet. The main switch or the socket must be near the appliance and easily accessible.

It is advisable to place the appliance under an extractor hood so that steam is extracted rapidly. If the appliance is placed near walls, dividing panels, kitchen furniture, decorative finishings, etc., these should be in flameproof material; otherwise it is necessary to cover them with non-flammable material.

Above all, it is necessary to ensure that the fire prevention norms are observed

LAWS, TECHNICAL RULES AND NORMS

Installation must be carried out observing the following norms:

- Safety prescription in force
- Installation prescription, ECI norms.

The installation, starting up and maintenance of the appliance must be carried out by qualified personnel. All operations done when installing must be carried out observing the norms in force.

The manufacturer declines all responsibility in the event of incorrect functioning due to

wrong installation or installation which does not comply with the norms.

Attention! In accordance with international rules, when connecting the appliance, an automatic device enabling the disconnection of all contacts from the mains, must be installed above it; this device must have a contacts opening of at least 3 mm.

ELECTRIC CONNECTION

The appliance is supplied without the connection cable.

To install the power supply cable, proceed as follows:

- Remove the back panel
- Disconnect the cable from the junction box which is situated at the back.
- Loosen the cable blocker and pull out the cable.
- Push the connection cable through the cable blocker, connect the conductor wires to the corresponding terminals in the junction box and fix them into place.
- Block the cable with the cable blocker, and reassemble the back panel. The earth wire must be longer than the others so that if the cable blocker should break, it will disconnect after the tension wires.

N.B. The connection cable must have the following characteristics: it must be at least type H05RN-F and must have an adequate section for the power of the appliance (see technical data table).

EQUIPOTENTIAL

The appliance must be connected to an equipotential system. The connection screw is positioned at the back of the appliance and is identified by the symbol .

Attention: The manufacturer will neither be held responsible for, nor will give any compensation during the guarantee period for any damage caused, and which is due to inadequate installations not compliant with the instructions.

STARTING UP

Before using the appliance for the first frying, it is necessary to clean it carefully, (see paragraph “cleaning and care”). Check the connection of the appliance and start it up following the instructions.

INSTRUCTIONS FOR USE

Attention!

- Use the appliance only under surveillance.
- Remember that whilst using glass ceramic tops, the crystal surfaces in the cooking area, increase the temperature considerably; it is therefore necessary to take this into consideration and act accordingly.
- It is advisable to use recipients with a flat bottom, as recipients with concave or rounded bottoms increase cooking time and energy consumption.

Indications:

- Each hotplate is connected to an energy regulator (selector), giving the possibility to choose from 6 different temperatures. For the first cooking, it is advisable to use the highest temperatures.
- each hotplate is provided with a temperature limiter which comes into function when the temperature reached may damage the crystal.
- When the crystal surface heats up, the residuous heat light comes on, corresponding to the hotplate in function. This indicator does not go off until the crystal maintains a high temperature, even with the hotplate turned off so as to avoid danger of burns.

Warnings:

- Do not use pans or any recipient with the bottom in aluminium or with a tin coating.
- Do not use terracotta pots as they could break or crack and therefore become unhygienic. It is advisable to use stainless steel pans with a smooth, flat bottom and with an adequate diameter for the heating area. If cast-iron pans are used, be careful not to slide them on the crystal, in order to avoid any scratches. Make sure that the bottom of the pans has been dried well before placing them on the top; avoid banging the crystal, especially with sharp or pointed objects.
- Pay attention never to cover the crystal with sheets of aluminium paper or anything similar, during use. Never start up the appliance without oil.

Any kind of food (meat, fish, legumes, eggs, rice, vegetables, etc.) can be cooked on the glass ceramic coking tops, providing suitable pans are used..

TURNING ON

Switch on the main switch installed above the appliance. Turn the control knob corresponding to the hotplate from position “0” to the degree of heating desired, between 1 and 6. The light comes on, as soon as the power supply is on.

The green light indicates the presence of electrical tension. To turn off the hotplate, turn the knob back into position “0”. The hotplates are made up of a nucleus and a crown.

Turning the knob, as indicated above, only the nucleus of the hotplate comes on; turning the knob beyond position “6”, the crown also comes on and the temperature can, once again be regulated from pos. “1” to pos. “6”.

CLEANING AND MAINTENANCE

Attention! During cleaning, do not wash the external parts of the appliance with direct sprays of water or with high pressure.

After every use, clean the appliance thoroughly. Daily cleaning after switching off the appliance ensures the perfect functioning and long life of the appliance.

Before starting to clean the appliance, disconnect the power supply. The parts in steel must be washed with hot water and neutral detergent, then rinsed thoroughly in order to eliminate all traces of detergent; after which, dried with a dry cloth. Do not use abrasive or corrosive detergents.

Cleaning the crystal

The crystal must be cleaned with degreasing liquids, acids containing vinegar and lemon, suitable for cleaning ceramic and crystal. It is advisable to carry out this operation when the crystal is not completely cold, so that spilled food, burned grease, etc. can be softened using a damp cloth and removed whilst still warm with an ordinary scraper, in order to avoid damaging the crystal surface.

Do not use abrasive or corrosive detergents.

CLEANING BURNISHED BRASS SURFACES

No synthetic protective varnishes have been used to obtain the special burnishing effect on the burnished brass details in order to avoid spoiling the beauty of the brass with an artificial patina. The antique finish of the surface is the result of natural oxidation that has simply been accelerated. All the natural antique finish brass surfaces can be cleaned with any kitchen degreasing detergent, accompanied by the use of an abrasive scouring pad (the green colored type used for washing dishes). It is recommended that the metal be rubbed, uniformly applying light pressure, until the desired effect is achieved.

The brass details should then be dried.

Do not use polish as this is suitable for maintaining the gloss but not the antique finish and could result in an effect that is not compliant with our products. Any spots that may appear over time on the burnished brass surfaces should be considered as a desirable and particular characteristic of our craft metal working processes.

CLEANING CHROMIUM-PLATED BRASS SURFACES

No synthetic varnishes have been used to obtain the special polish on the chromium-plated brass details in order to avoid spoiling the beauty of the chromium plating with an artificial patina. All the chromium-plated surfaces should be cleaned, where necessary, with a soft, possibly micro-fiber cloth, combined with metal polishing products, if required. Do not use abrasive pads.

CLEANING SATIN FINISH NICKEL-PLATED BRASS SURFACES

No synthetic varnishes have been used to obtain the special nickel-plating on the satin finish nickel-plated brass details in order to avoid spoiling the beauty of the nickel-plated,

satin finished solid brass with an artificial patina. All the nickel-plated and satin finished brass surfaces should be cleaned, where necessary, with a soft, possibly micro-fiber cloth, combined with a neutral detergent, if required. Do not use abrasive pads.

CLEANING THE VARNISHED SURFACES

All the varnished surfaces should be cleaned using a neutral detergent and, where necessary, a soft, possibly micro-fiber cloth. Do not use abrasive pads or any other chemical products.

CLEANING BRUSHED STEEL SURFACES

All the brushed steel surfaces should be cleaned using degreasing products or products specifically designed to be used on steel and, where necessary, extra-fine steel wool or extra-thin sandpaper.

PROCEDURE TO FOLLOW IF THE APPLIANCE IS NOT GOING TO BE USED FOR SOME TIME

Clean and dry the appliance carefully according to the instructions. Disconnect the power supply.

PROCEDURE TO FOLLOW IN THE EVENT OF A BREAKDOWN

In the event of breakdown, turn off the appliance, disconnect the power supply by using the device situated above the appliance and notify the after sales service.

MAINTENANCE (ONLY FOR QUALIFIED PERSONNEL)

Any kind of maintenance must only be done by qualified personnel. Before carrying out maintenance, remove the plug or switch off the switch above the appliance.

ACCESSIBILITY

To get to the junction-box, remove the back of the appliance. The control elements are reached from the front control panel; unscrew the fixing screws from the control panel and remove it.



en

INTERNATIONAL

V 2.1 - 10. 17

OFFICINE GULLO S.R.L.: via della Torricella 29, 50012 Antella - Bagno a Ripoli (FI)

Tel. +39 055 6560324 / 621807 - Fax + 39 055 620670 - info@officinegullo.com

WWW.OFFICINEGULLO.COM