



OFFICINE GULLO
FIRENZE



BBS4G

BBS8G

GAS BARBECUE FOR
RESIDENTIAL AND PROFESSIONAL USE

INSTRUCTIONS
for installation and use

CAUTION

1. These safety directions apply to different kinds of appliances. Please identify correctly the specific appliance in your possession (check the tag showing the characteristics).
2. Before using the appliance, read the instruction manual carefully, as it contains important safety information on the proper installation, use and maintenance of the appliance. Please keep the instruction manual for further reference.
3. The appliance's electrical safety is guaranteed only if the electrical system is earthed in accordance with the relevant regulations. It is of the utmost importance to follow such regulations; when in doubt, please consult a qualified electrician to have the electrical system thoroughly checked. The manufacturer declines all responsibility for damage caused by a badly-earthed electrical system
4. Before connecting the appliance, make sure that the appliance's technical characteristics shown on the tag correspond to those of the electrical system and gas distribution network.
5. Make sure that the electrical system and sockets can handle the appliance's maximum power consumption as shown on the tag. When in doubt, please consult a qualified electrician.
6. The appliance should be connected to the electric supply line by means of an omnipolar switch with a minimum contact opening of 3 mm
7. If the power socket is not compatible with the plug, replace the socket with a proper one and consult a qualified electrician to make sure that the cable size can handle the appliance's maximum power consumption. The use of adapters, multiple power boards and extension cords is not recommended.
8. When not in use, switch off the general power supply to the appliance and close the gas supply valve.
9. Do not obstruct the appliance's cooling or heat dissipation vents.
10. In case of damage to the appliance's power cord, it must be replaced exclusively by the manufacturer's authorized service center.
11. The appliance must be used only for the purposes for which it has been expressly designed (cooking). All other uses (such as the heating of a room) are considered inappropriate and therefore dangerous. The manufacturer declines all responsibility for damage resulting from improper use of the appliance.
12. The use of any electric appliance implies the observance of some basic rules. More specifically:
 - A. Do not touch the appliance with wet or damp hands or feet;
 - B. Do not use the appliance with bare feet;
 - C. Avoid the use of extension cords and, if necessary, take all precautions;
 - D. Do not pull the power cord to disconnect the plug from the power socket;
 - E. Do not leave the appliance exposed to atmospheric agents (rain, sun, etc.);
 - F. Do not allow children or untrained persons to use the appliance.
13. Before cleaning the appliance or performing maintenance work, disconnect the appliance by pulling the plug out of the power socket or turning off the main switch.
14. In case of failure or malfunction, turn the appliance off, close the gas supply valve and do not attempt to carry out any repairs, which must be done exclusively by an authorized service center.

Request the use of original spare parts only. Failure to comply with the above recommendations may compromise the appliance's safety

FIG.A

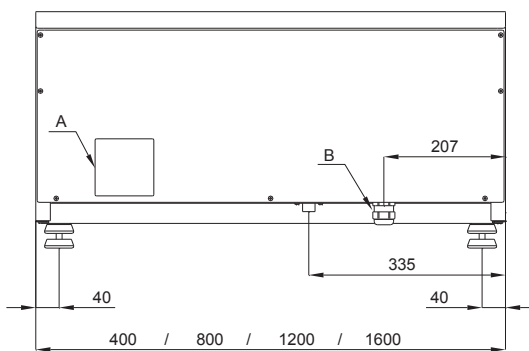
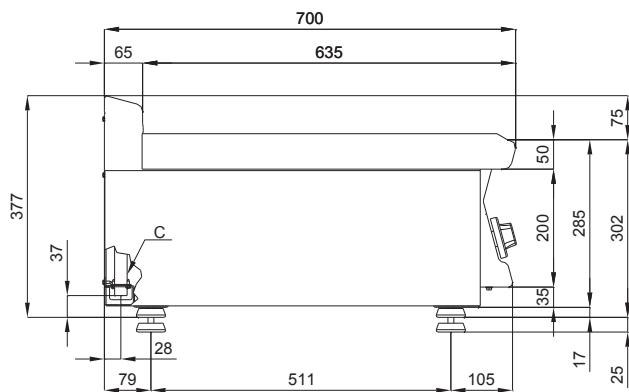

A. Data plate

C. Gas Connection ISO 7-1 R1/2GM

FIG.B

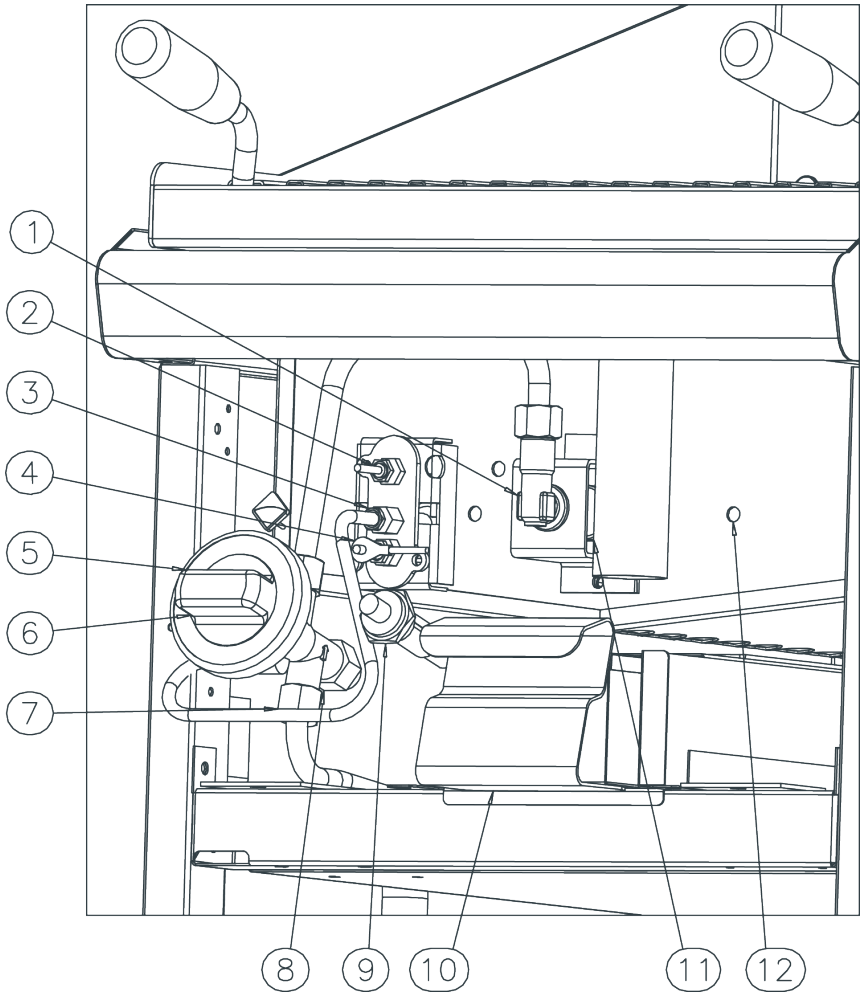

- | | |
|------------------------|-------------------------|
| 1. Injector | 7. Tap |
| 2. Thermocouple | 8. Piezoelectric device |
| 3. Pilot | 9. Drip pan |
| 4. Lighting spark plug | 10. Burner |
| 5. Knob | 11. Tub |
| 6. Gas pipes | |

INDEX

DECLARATION OF COMPLIANCE.....	6
TECHNICAL GAS DATA TABLE.....	6
INSTALLING THE APPLIANCE	6
CHECKING FOR ADEQUATE VENTILATION.....	6
PIPE FOR GAS CONNECTION	7
CHECKING HEAT OUTPUT.....	7
CHECKING PRIMARY AIR IN MAIN BURNERS	8
TECHNICAL BURNERS DATA TABLE.....	8
RULES FOR CONVERTING AND INSTALLING OTHER TYPES OF GAS.....	8
REGULATING MINIMUM OUTPUT.....	8
SUBSTITUTING THE NOZZLE IN THE MAIN BURNER.....	8
SUBSTITUTING THE NOZZLE IN THE PILOT BURNER	9
CHECKING FUNCTIONING	9
MAINTENANCE.....	9
SPARE PARTS	9
LIGHTING AND ADJUSTING THE MAIN BURNER	10
CLEANING AND MAINTENANCE.....	10
WHAT TO DO IN THE EVENT OF A BREAKDOWN	10
PROCEDURE TO FOLLOW IF THE APPLIANCE IS NOT GOING TO BE USED FOR SOME TIME	11
INSTRUCTIONS FOR DISCHARGING GAS EMISSIONS	12

DECLARATION OF COMPLIANCE

The manufacturer declares that the appliances are compliant with the prescriptions of the EEC norm 2009/142. The installation must be done observing the norms in force particularly concerning room ventilation and discharging gas emissions.

N.B.: The manufacturer declines any responsibility for direct or indirect damage caused by improper or incorrect installation, maintenance or use of the appliance and alterations, as in all the other cases considered in the items of our sales conditions

TECHNICAL GAS DATA TABLE

MODEL	Dimensions cm	Nominal Power TOT. kW	Gas Connection ISO 7-1
BBS4G	40x70x29h	9	R ½G
BBS8G	80x70x29h	18	R ½G

INSTALLING THE APPLIANCE

- The operations for installing, conversions for use with other types of gas and starting up must be done only by qualified personnel whose qualifications comply with the norms in force.
- The gas installation, the electrical connections and the rooms in which the appliances are installed must comply with the norms in force in the Country in which the installation is carried out; above all, the appliance must be installed in a well ventilated room, preferably under an extractor hood, so as to ensure the complete extraction of gas emissions which are formed during combustion. The air necessary for combustion is 2m³/h per kW of power installed.

CHECKING FOR ADEQUATE VENTILATION

Make sure that the air intake into the room where the appliance is installed is sufficient for an adequate change of air, as specified by regulations in effect.

The appliances installed in buildings open to the public must satisfy the following requirements.

Installation rules

The installation and maintenance of the appliance must be done according to the correct procedures and regulation texts in use, particularly:

- **safety standards for the prevention of fire and panic.**

Connection and installation of appliance, ventilation and exhaust removal systems, shall be done according to the Manufacturer's instructions and by qualified technicians and according to the regulations in effect. The electric wiring shall conform to the regulations in effect.

All fire prevention codes shall be observed.

a) General indications (**Rules valid for GB only**)

- **For all appliances:**

Gas safety Regulations, 1984; Health and safety at Work Act, 1974 Codes of Practice, BS 8173, 1982, The Building

Regulations 1985; The Building Standards Regulations, 1981, the IEE Regulations and the by-laws of the local Water Undertaking.

The local gas Region or LPG supplier and the local authority and the relevant recommendation of the British Standards (latest editions) concerned.

The installation, transformation and repair of appliances for professional kitchens as well as removal due to malfunction, and the supply of gas, may be made only by means of a maintenance contract stipulated with an authorized sales office and in observance of technical regulations.

The appliance can be installed by itself or in a series side by side with appliances produced by us. There must be a minimum distance of at least 10 cm between the appliance and the sides of the nearby cabinets made of inflammable material.

Take suitable measures to guarantee thermal insulation of the inflammable sides, such as, for example, the installation of protection against radiation.

The appliances must be installed in a suitable manner, observing the safety standards.

The small feet are adjustable to level the appliance.

PIPE FOR GAS CONNECTION

The gas connection must be effected with steel or copper pipes, or otherwise with flexible steel pipes in compliance with the national norms, if any exist. Each appliance must be provided with a cutoff cock for rapid interruption of the gas supply. Once the appliance has been installed, it is necessary to check for gas leaks for the pipe fittings; do not use a flame for this purpose but a non-corrosive substance such as soapy water or foamy substances as contained in leakfinder sprays. All our appliances undergo careful testing: the type of gas, the operating pressure and the category are indicated on the data plate.

CHECKING HEAT OUTPUT

The appliances must be checked in such a way as to verify that the heat output is correct:

- The heat output (thermal power) is indicated on the data plate of the appliance.
- Firstly, check that the appliance can be used with the type of gas supplied; then check that the indication on the plate corresponds to the gas to be used. For converting to another type of gas, check that the type of gas complies with what is stated in this instruction manual.

The pressure must be read by inserting a gauge for liquids (e.g. a U gauge). With a minimum definition of 0,1 mbar, into the relative pressure outlet.

Remove the screw from the airtight pressure outlet, connect the rubber pipe of the U gauge and read the pressure.

After reading, remove the flexible pipe of the gauge, put back the screw, tighten hermetically and check the pressure tightness.

Connection for liquid gas G30/G31

The connection pressure for liquid gas is 30 mbar with butane and 37 mbar with propane. Check the plate, read the pressure and verify that the description of the nozzle installed corresponds to the one supplied by the manufacturer.

Connection with natural gas H G20

The connection pressure for natural gas is 20 mbar. Check the plate, read the pressure and verify that the description of the nozzle installed corresponds to the one supplied by the manufacturer.

CHECKING PRIMARY AIR IN MAIN BURNERS

All the burners are provided with a bush for regulating the primary air which must be positioned at a distance h indicated in the technical data table.

TECHNICAL BURNERS DATA TABLE

BBS4G 1 burner BBS8G 2 burners (max 9 kW min. 2,7 kW)	12,68 kWh/kg G30 BUTANE 28 mbar	12,87kWh/kg G31 PROPANE 37 mbar	9,45 kWh/m ³ st. G20 NATURAL GAS 20 mbar
Burner Injector 1/100 mm	150	150	220
Min. output adjustment 1/100 mm	70	70	adjustable
Pilot Injector	30	30	51
Primary air h =mm	17	17	17
Consumption	kg/h 0,710	kg/h 0,699	m ³ st./h 0,952

RULES FOR CONVERTING AND INSTALLING OTHER TYPES OF GAS

Our appliances are tested and regulated for liquid gas (see plate inside).

The conversion or adaptation to another type of gas must be carried out by a specialized technician. The nozzles for the various types of gas are in a packet supplied with the appliance and are marked in hundredths of mm (see the technical data table).

REGULATING MINIMUM OUTPUT

After having carried out the conversion for another type of gas, it is necessary to regulate minimum output by turning the screw to the right or to the left until the minimum heat output reaches 2,7 kW.

SUBSTITUTING THE NOZZLE IN THE MAIN BURNER

- Remove the front fixing screws from the panel, remove the start-up cable from the piezoelectric ignition device
- Using a suitable spanner, unscrew the nozzle and substitute it with the right one (see the technical data table).

SUBSTITUTING THE NOZZLE IN THE PILOT BURNER

The flame of the pilot burner has fixed air.

The only operation necessary is the substitution of the nozzle according to the type of gas.

It is therefore necessary to unscrew the screws as specified in the previous point; with a suitable spanner unscrew the fitting and substitute the nozzle with a suitable one. With the right nozzle, the flame must lap the thermocouple.

Important!

After having carried out the conversion to another type of gas, it is necessary to update the data plate, indicating the type of gas for which the appliance has been converted.

CHECKING FUNCTIONING

- The appliance contains the instructions necessary for use.
- Check the appliances for gas leaks.
- Examine the flame of the pilot burner; it must lap the thermocouple and be blue, otherwise examine the nozzle of the pilot burner.
- Check the lighting and flame of the main burner.
- We urge the user to follow the instructions when using the appliance.

MAINTENANCE

With prolonged use of the appliance, it is essential to carry out regular maintenance for the safe functioning of the appliance; we therefore recommend drawing up a contract for after sales service. Maintenance must be done only by specialized personnel, observing the norms in force and our indications.

SPARE PARTS

It is possible to substitute parts such as: gas cock, piezoelectric device or gas piping in a very simple way. To substitute the parts, proceed as follows:

- Cock: after taking off the front panel, unscrew the screwed fittings from the gas connections and the thermocouple fitting, after which, substitute the cock.
- To substitute the thermocouple, unscrew the fitting of the pilot burner, likewise unscrew the thermocouple fitting and substitute the element.
- The spark plug must be unscrewed and substituted.

INSTRUCTIONS FOR USE

Attention: In the event that smoke is given off when the appliance is started up, it is necessary to leave the appliance on without being used for approximately an hour or until the smell disappears.

DRIP PAN

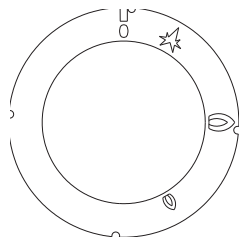

The drip pan must be checked regularly and emptied before getting full. In any event, the pan must be cleaned after switching off the appliance.

LIGHTING AND ADJUSTING THE MAIN BURNER



On the front panel, above each knob, the burner it corresponds to is indicated by the index

To light, turn the knob to the left from position "0" to the symbol (see figure);

keep it pushed down and press the button with the symbol until  the gas lights 

Keep the knob pressed a few second and then let it go, this lights the pilot.

If the flame goes out you have to repeat the procedure.

By turning the knob round to the position the burner is at maximum 

By turning the knob round to the position the burner is at minimum. 

To switch off, move the knob back into position "0".

Turning off the appliance

Push and turn the knob into position "0". This command blocks the gas supply to both the main burner and the pilot burner. To relight the appliance, it is necessary to turn the knob again into position * and press the button.

CLEANING AND MAINTENANCE

Attention! During cleaning, do not wash the external parts of the appliance with direct sprays of water or with high pressure.

Daily cleaning after switching off the appliance ensures the perfect functioning and long life of the appliance. The parts in steel must be cleaned with a detergent-soaked cloth without rubbing; after that, rinse with clean water and dry with a dry cloth.

Do not use abrasive or corrosive detergents.

Important: As well as ordinary cleaning and maintenance, it is advisable to have the installation checked by an installer at least once a year.

It is therefore suggested to draw up an after-sales assistance contract.

CLEANING BURNISHED BRASS SURFACES

No synthetic protective varnishes have been used to obtain the special burnishing effect on the burnished brass details in order to avoid spoiling the beauty of the brass with an artificial patina. The antique finish of the surface is the result of natural oxidation that has simply been accelerated. All the natural antique finish brass surfaces can be cleaned with any kitchen degreasing detergent, accompanied by the use of an abrasive scouring pad (the green colored type used for washing dishes). It is recommended that the metal be rubbed, uniformly applying light pressure, until the desired effect is achieved.

The brass details should then be dried.

Do not use polish as this is suitable for maintaining the gloss but not the antique finish and could result in an effect that is not compliant with our products. Any spots that may appear

over time on the burnished brass surfaces should be considered as a desirable and particular characteristic of our craft metal working processes.

CLEANING CHROMIUM-PLATED BRASS SURFACES

No synthetic varnishes have been used to obtain the special polish on the chromium-plated brass details in order to avoid spoiling the beauty of the chromium plating with an artificial patina. All the chromium-plated surfaces should be cleaned, where necessary, with a soft, possibly micro-fiber cloth, combined with metal polishing products, if required. Do not use abrasive pads.

CLEANING SATIN FINISH NICKEL-PLATED BRASS SURFACES

No synthetic varnishes have been used to obtain the special nickel-plating on the satin finish nickel-plated brass details in order to avoid spoiling the beauty of the nickel-plated, satin finished solid brass with an artificial patina. All the nickel-plated and satin finished brass surfaces should be cleaned, where necessary, with a soft, possibly micro-fiber cloth, combined with a neutral detergent, if required. Do not use abrasive pads.

CLEANING THE VARNISHED SURFACES

All the varnished surfaces should be cleaned using a neutral detergent and, where necessary, a soft, possibly micro-fiber cloth. Do not use abrasive pads or any other chemical products.

CLEANING BRUSHED STEEL SURFACES

All the brushed steel surfaces should be cleaned using degreasing products or products specifically designed to be used on steel and, where necessary, extra-fine steel wool or extra-thin sandpaper.

WHAT TO DO IN THE EVENT OF A BREAKDOWN

Turn off the gas tap and notify the after sales service.

OBSERVATIONS AND ADVICE

With appliances which have two cooking areas (BBS8G), it is possible to diversify the temperature in the two halves of the grill, or to use only one half. Use the appliance only under surveillance.

PROCEDURE TO FOLLOW IF THE APPLIANCE IS NOT GOING TO BE USED FOR SOME TIME

Turn off the gas tap and clean the appliance as specified above.

MAINTENANCE (only for qualified personnel)

Any kind of maintenance must only be done by qualified personnel. Before carrying out maintenance, remove the plug or switch off the switch above the appliance.

INSTRUCTIONS FOR DISCHARGING GAS EMISSIONS

Type “A” Appliances (See data plate)

Type “A” appliances must discharge the products of combustion into extractor hoods or similar devices connected to and efficient chimney, or directly outside.

(Natural Discharge) Fig.1.

If there is no hood, as an alternative, an air extractor connected directly to the outside is acceptable, **(Forced Discharge)** Fig.2, but its capacity must not be inferior to what is established in item 4.3 of the UNI-CIG norm 8723.

In the event of forced discharge

The gas supply to the appliance, must be directly interlocked to the system and cut off automatically if its capacity drops below the values prescribed by item 4.3 of the UNI-CIG norm 8723.

Supplying the appliance with gas again must only be possible manually.

NATURAL DISCHARGE

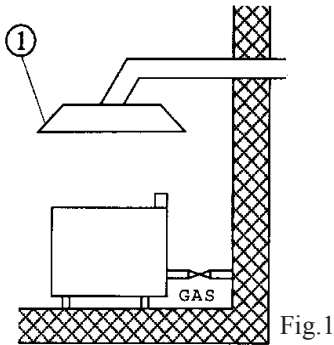

Fig.1

1. Extractor hood

FORCED DISCHARGE

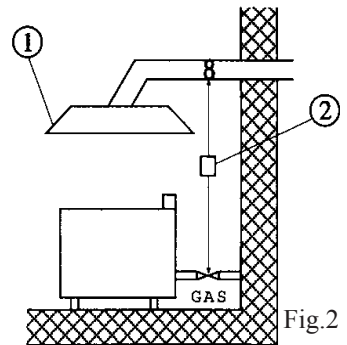

Fig.2

1. Extractor hood
2. Interlocking



en

INTERNATIONAL

V 2.0 - 05. 2016

OFFICINE GULLO S.R.L.: via della Torricella 29, 50012 Antella - Bagno a Ripoli (FI)

Tel. +39 055 6560324 / 621807 - Fax + 39 055 620670 - info@officinegullo.com

WWW.OFFICINEGULLO.COM