

# 70

ESSENTIAL SERIES

## ACUTAOG03L

KITCHEN FAUCET

OFFICINE GULLO  
FERRARA

### DESCRIZIONE DESCRIPTION



### KITCHEN FAUCET

### DATI TECNICI TECHNICAL INFO

|   |  |
|---|--|
| TOP SPESSORE MASSIMO - TOP THICKNESS MAXIMUM                | 1 15/16"                                     |
| TOP SPESSORE MINIMO - TOP THICKNESS MINIMUM                 | 3/8"   |
| NUMERO FORI - NUMBER OF HOLES                               | 2  |
| DIAMETRO FORO - FITTING HOLE DIAMETER                       | 1 13/8" - 1 9/16" / lever 1 9/16" - 1 13/16" |
| DISTANZA TRA COLLEGAMENTI MIN - INLET SUPPLY SPREAD MINIMUM | 8 7/8"                                       |
| DISTANZA TRA COLLEGAMENTI MAX - INLET SUPPLY SPREAD MAXIMUM | 14 9/16" in                                  |
| COLLEGAMENTO IDRICO - HOSE OR INLET CONNECTION SIZE         | 9/16" female NPT (USA)                       |
| LUNGHEZZA ATTACCO FLESSIBILE - HOSE CONNECTION LENGTH       | 21" 11/16                                    |
| ALTEZZA TOTALE - TOTAL HEIGHT                               | 15 5/16"                                     |
| ALTEZZA GETTO - SPOUT HEIGHT                                | 9 7/8"                                       |
| LUNGHEZZA GETTO - SPOUT REACH                               | 9 1/16"                                      |
| PORTATA - FLOW RATE   | 1.2 gpm                                      |
| GETTO GIREVOLE - SPOUT SWIVEL                               | Yes  |
| NUMERO MANOPOLE - NUMBER OF HANDLES                         | 1+lever                                      |
| MATERIALE BASE - PRIMARY MATERIAL                           | Brass  |
| TIPO INSTALLAZIONE - INSTALLATION TYPE                      | TOP Mounted                                  |
| MATERIALE VALVOLA - VALVE MATERIAL                          | Ceramic                                      |
| PRESSIONE DELL'ACQUA - WATER PRESSURE                       | 70.0 / 20.0 / 45.0 psi                       |
| SUGGERITO APPLICATION                                       | Bar, Kitchen, Laundry                        |
| HANDLE SPREAD MINIMUM                                       | 15" 3/4                                      |
| HANDLE SPREAD MAXIMUM                                       | 21" 5/8                                      |

### DISEGNO TECNICO TECHNICAL DRAWINGS

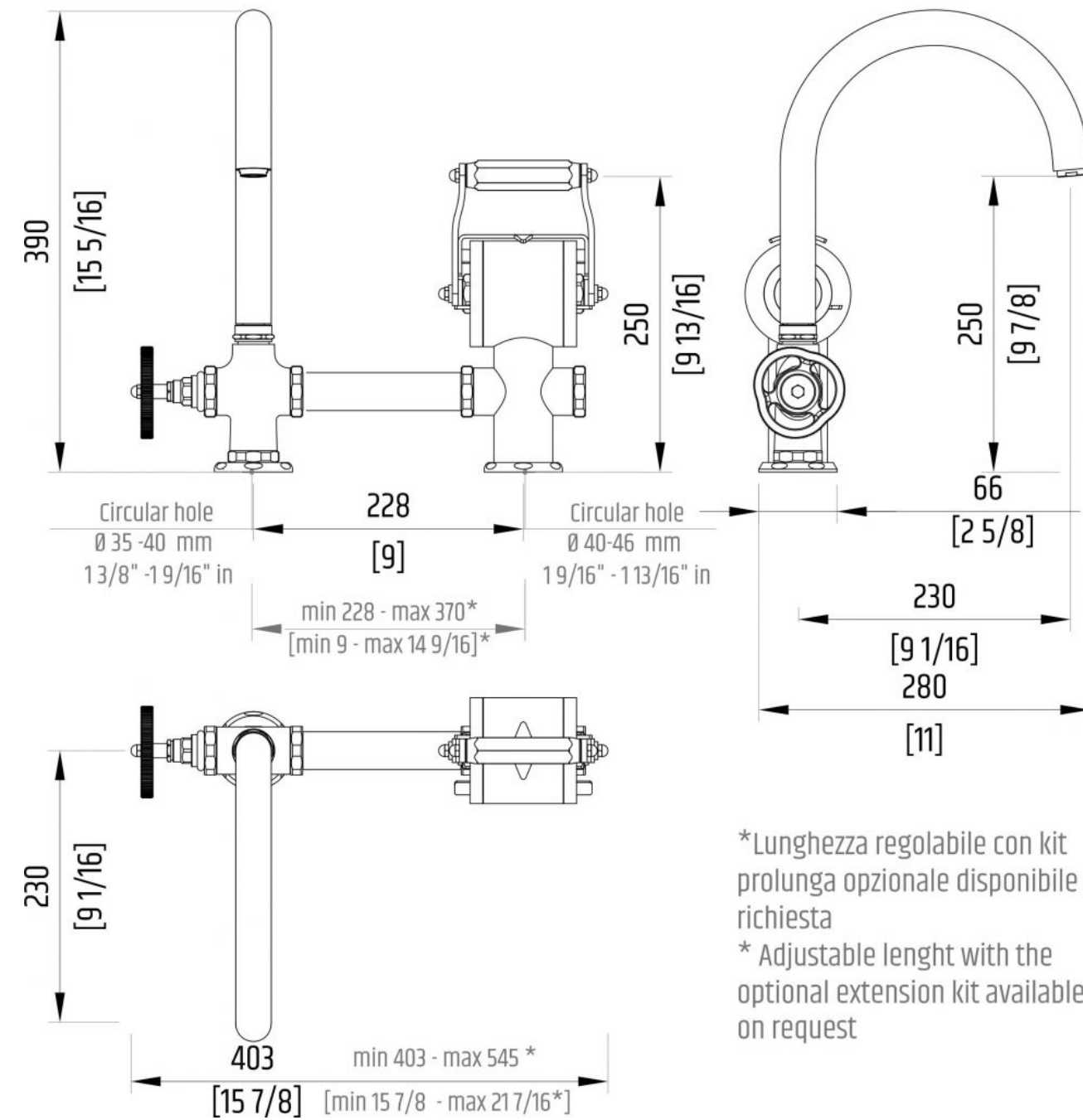

\*Lunghezza regolabile con kit prolunga opzionale disponibile su richiesta  
\* Adjustable length with the optional extension kit available on request